

---

**MICRODRIVE**<sup>™</sup>  
*Elite*

**ULTRADRIVE**<sup>™</sup>  
*Elite*

**ELITE SERIES  
GETTING STARTED  
MANUAL**

**PDL ELECTRONICS LTD**  
*Leaders in AC Motor Control*



## Contents

<b>Section 1: Unpacking, Installation and Connection</b>	<b>4</b>
<b>1.1 Unpacking your Elite Series</b>	<b>5</b>
1.1.1 Unpacking the Elite Series	5
1.1.2 Disposal of Packaging	5
<b>1.2 Installation of the Elite Series</b>	<b>5</b>
1.2.1 Installation Environment	5
1.2.2 Mounting Methods	7
<b>1.3 Connecting the Elite Series</b>	<b>11</b>
1.3.1 Power Wiring	11
1.3.2 Motor Rotation	13
1.3.3 Display Mounting	13
1.3.4 Control Wiring	13
1.3.5 Earthing of Control 0V	13
1.3.6 Shaft Encoder Selection and Mounting	13
1.3.7 Fibre Optic Connections	15
1.3.8 Rubber Control Cable Grommets	15
1.3.9 External Powering of the Control Board	15
1.3.10 Gland Plate and Front Cover Recommended Screw Torques	15
<b>Section 2: Operation of the Display Unit</b>	<b>18</b>
<b>2.1 Display Unit Description</b>	<b>19</b>
2.1.1 The Display Unit and Keys	19
2.1.2 Selection of Screens	19
2.1.3 Parameter and Mode Adjustment	20
<b>2.2 Configuring of Operating Mode</b>	<b>20</b>
2.2.1 Operating Modes	21
2.2.2 Swapping Between OPERATION and COMMISSIONING Modes	21
2.2.3 Setting a Password for the First Time	22
<b>Section 3: Preliminary Commissioning of the Elite Series</b>	<b>24</b>
<b>3.1 Commissioning Without Motor</b>	<b>25</b>
3.1.1 Foreword	25
3.1.2 Checks Before Powering up	25
3.1.3 Applying Power to the Elite Series	25
<b>3.2 Preliminary Control Setup</b>	<b>25</b>
3.2.1 Foreword	26
3.2.2 Checking of Analogue Inputs	26
3.2.3 Checking of Analogue Outputs	26
3.2.4 Checking of Digital Inputs	27
3.2.5 Checking of Digital Outputs	28
3.2.6 Preliminary Setup	28

3.2.7	Shaft Encoder Configuration	29
3.2.8	Dynamic Brake Configuration (if fitted)	29
3.2.9	Checking of Fibre Optic Input	30
3.2.10	Checking of Serial Input	30
<b>3.3</b>	<b>Energising the Motor</b>	<b>30</b>
3.3.1	Connecting the Motor	30
3.3.2	Checking the Shaft Encoder (if fitted)	30
3.3.3	Autotuning	31
3.3.4	Preliminary Commissioning Complete	31

## **Section 4: Final Commissioning of the Elite Series** **31**

<b>4.1</b>	<b>Operation Mode and Configuration</b>	<b>32</b>
4.1.1	Operation Modes	33
4.1.2	Input Configuration	34
4.1.3	Output Configuration	34
4.1.4	Acceleration and Deceleration Rates	35
4.1.5	Speed and Torque Limits	35
4.1.6	Multi-references	35
<b>4.2</b>	<b>Closed Loop Vector Speed Loop Tuning</b>	<b>36</b>
4.2.1	Speed Loop Proportional Gain (Screen X4f)	36
4.2.2	Speed Loop Integral Gain (Screen X4g)	36
4.2.3	Speed Loop Derivative Gain (Screen X4h)	36
4.2.4	Use of Analogue Output in Tuning Speed Loop	36

### **List of Figures**

Figure 1.1:	Elite Series Dimensions and Weights	6
Figure 1.2:	Full Load Dissipation and Cooling Air Flow Rates	7
Figure 1.3:	Mounting Details for Elite Series	8-10
Figure 1.4:	Power Wiring and Dynamic Brake Connections	12
Figure 1.5:	Fuse Rating Table	12
Figure 1.6:	Shaft Encoder Connection Details	14
Figure 1.7:	External Powering of Control Board	15
Figure 1.8:	Control Inputs and Outputs	16-17
Figure 2.1:	Elite Series Display Unit	19
Figure 2.2:	Control of Screen Folding	20
Figure 2.3:	Setting Commission Mode after a Password has been set	22
Figure 2.4:	Setting a Password for the First Time	23
Figure 3.1:	Screens Z3, Z4 – Analogue Input Status	26
Figure 3.2:	Screens Z5, Z6 – Analogue Output Status	27
Figure 3.3:	Screen Z7 – Digital Input Status	28
Figure 3.4:	Screen Z10 – Digital Output Status	28
Figure 4.1:	Elite Series Operation Modes	34
Figure 4.2:	Default Screen Lists A-H	37
Figure 4.3:	Default Screen Lists I-M	38
Figure 4.4:	Default Screen Lists N-P	39
Figure 4.5:	Default Screen Lists R-Z	40

# **Section 1: Unpacking, Installation and Connection**

---

# 1.1 Unpacking your Elite Series

## 1.1.1 Unpacking the Elite Series

On unpacking, check that all listed items are present and undamaged.

- Item 1: Elite Series motor controller
- Item 2: Elite Series Getting Started Manual (Part No. 4201-179)  
(This manual)
- Item 3: Elite Series Technical Manual (Part No. 4201-180)

If the Elite Series motor controller appears to be damaged, file a report with your carrier.

If any documentation is not present, contact your local PDL Electronics supplier or distributor.

## 1.1.2 Disposal of Packaging

All packaging materials made from cardboard and/or wood are able to be recycled at your local recycling centre.

# 1.2 Installation of the Elite Series

## 1.2.1 Installation Environment

Figure 1.1 details the dimensions and weights of the Elite Series range of induction motor controllers. The ambient temperature of the installation location must not exceed 50°C (122°F). An ambient temperature below 40°C (104°F) is preferable, for longer component lifetime, and to enable extra output rating to be achieved for pump and fan installations.

The internal components of the Elite Series are sealed from the cooling air. Thus the drive is protected against an environment contaminated to pollution degree 3 (damp or dusty air).

Each Elite Series motor controller must have cooling air available and will contribute to heating the environment in which it is mounted. Details are given in Figure 1.2 from which the total cooling load should be calculated. Any air conditioning or ventilation system used in the plant room must be capable of handling this load, plus that caused by any other dissipative devices in the same room, while keeping the ambient air temperature below 40°C to 50°C (104°F to 122°F). The air delivery system must be able to handle the total calculated air flow, with allowance made for system back pressure.

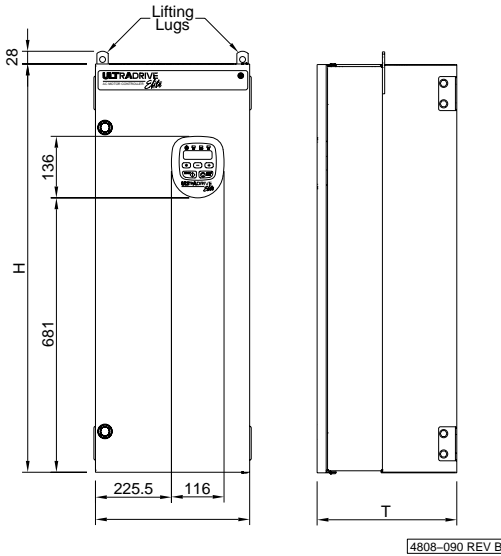
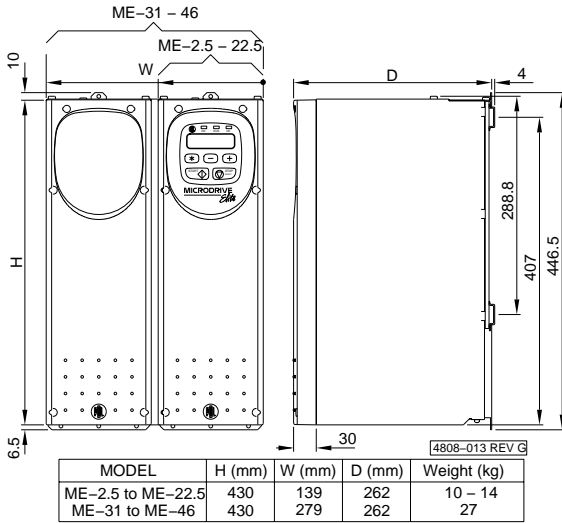

Figure 1.1: Elite Series Dimensions and Weights

MODEL	FULL LOAD DISSIPATION (W)	COOLING AIR FLOW RATE (cubic m / hr)
ME-2.5	55	200
ME-6.5	140	200
ME-10.5	220	200
ME-12	250	200
ME-18	330	200
ME-22.5	465	200
ME-31	640	400
ME-38	780	400
ME-46	950	400
UE-60	1100	400
UE-75	1300	400
UE-90	1600	400
UE-115	2000	400
UE-140	2500	400

4202-156 Rev E

*Figure 1.2: Full Load Dissipation and Cooling Air Flow Rates*

## 1.2.2 Mounting Methods

The Microdrive Elite Series range (2.5A to 46A) is designed for wall or switchboard mounting.

Allowable mounting methods are:

- (Standard) vertical, back to wall, with gland plate at bottom. Steel DIN rail mounting at top, screw fixing at bottom.
- Inverted mounting, with gland plate at top. Steel DIN rail mounting at centre, screw fixing at top.
- Vertical mounting, side to wall. Use extra mounting brackets.
- Horizontal mounting. Steel DIN rail mounting at centre, screw fixing at sides.

The Ultradrive Elite Series range (60A to 140A) is designed for wall or switchboard mounting.

The mounting must be:

- Vertical back to wall, with gland plate at bottom.

- 4 x M8 high tensile bolts must be used for fixing to wall.  
Note that eyelets are provided to allow prefixing of the mounting bolts before fitting of the Elite series.
- Wall/switchboard gear plate must be designed for the weight of the Elite Series and power cables.

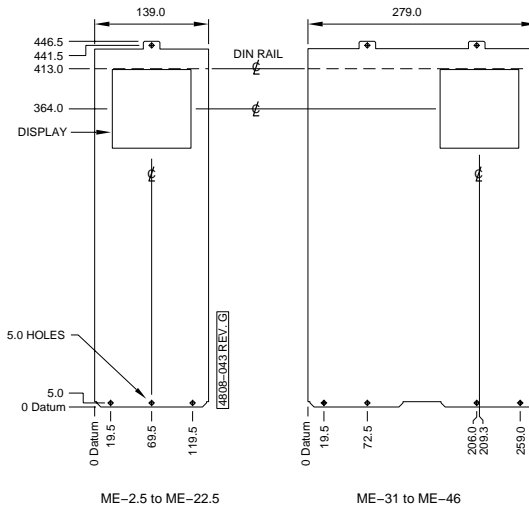

**Figure 1.3a: Standard Mounting Details for Elite Series (2.5A to 46A)**



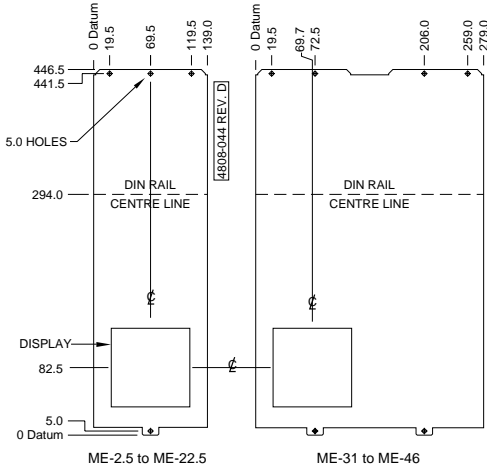

Figure 1.3b: Inverted Mounting Details for Elite Series (2.5A to 46A)

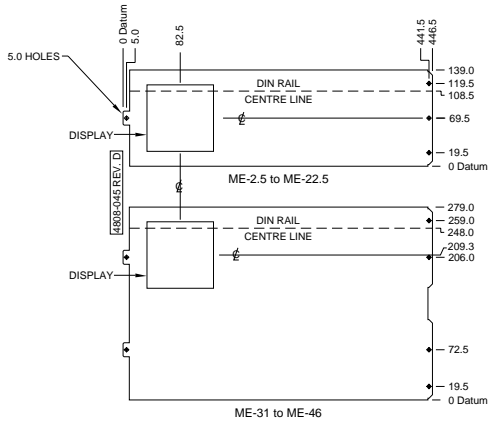

Figure 1.3c: Horizontal Mounting Details for Elite Series (2.5A to 46A)

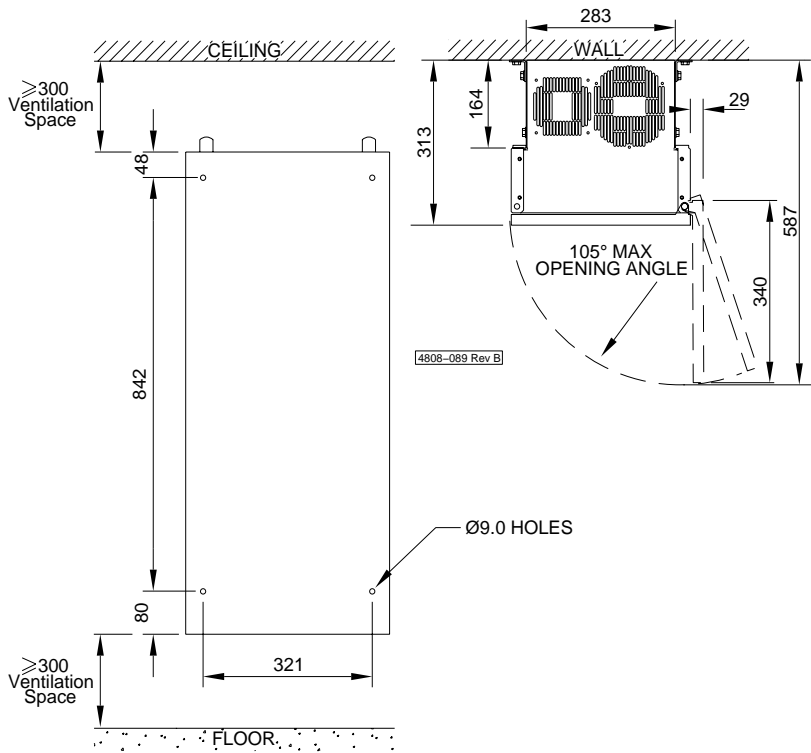

Figure 1.3d: Ultradrive Elite Series Mounting Details

## 1.3 Connecting the Elite Series

Remove the terminal cover for access to the gland plate and terminals. All external wiring should be passed through the gland plate supplied. Glands must be correctly fitted to the cables and the gland plate screws tightened to the recommended torque of 3.5Nm to preserve the IP54 rating of the Elite Series.

### 1.3.1 Power Wiring

**WARNING:**

ENSURE SUPPLY IS ISOLATED BEFORE WIRING UP

Refer to Figure 1.4 for power wiring details. The following notes refer to the drawing.

1. The Elite Series is designed for operation from a three phase earthed neutral supply. The drive and its cooling fans are not phase sequence sensitive. Input fuses must be installed. Fuses must be a general purpose LV h.r.c type intended for distribution circuits, of a voltage rating to suit the supply (typically 440Vac - 600Vac). Fuse ratings are shown in Figure 1.5.
2. Power factor correction capacitors are not required on the Elite Series input, and must not be connected to the Elite Series output.
3. An off load isolation switch or contactor may be fitted to the Elite Series output. Never attempt to operate this isolator under load. The Elite Series operates as a current source and opening the output while running could cause extensive damage or fire in the switchgear.
4. To maintain electromagnetic compatibility use screened cable (e.g. neutral screen, steel conduit) on the Elite Series output. Bond the screen solidly to the drive and motor chassis. Run the output cables separately from the input cables to reduce the chance of RFI cross-coupling. Failure to use screened output cables may lead to disruption of other electronic equipment.
5. The Elite Series protects the motor with an electronic overload, so an external overload relay is not necessary. Where multiple motors are attached, separate overload protection must be applied to each motor.
6. The Elite Series output waveform can give rise to high (capacitive) earth leakage currents. Permanent earth connection of both the motor and the Elite Series is essential before connection to the supply.
7. For applications where regeneration is likely to occur, a dynamic brake resistor may be required. The resistor must be positioned so that any heat generated by it will not ignite or damage its surroundings. Refer to the Elite Series Technical Manual (PDL Part No. 4201-180) for dynamic brake setup information.
8. The location and order of the power terminals varies from model to model. Refer to the terminal labels before connection.

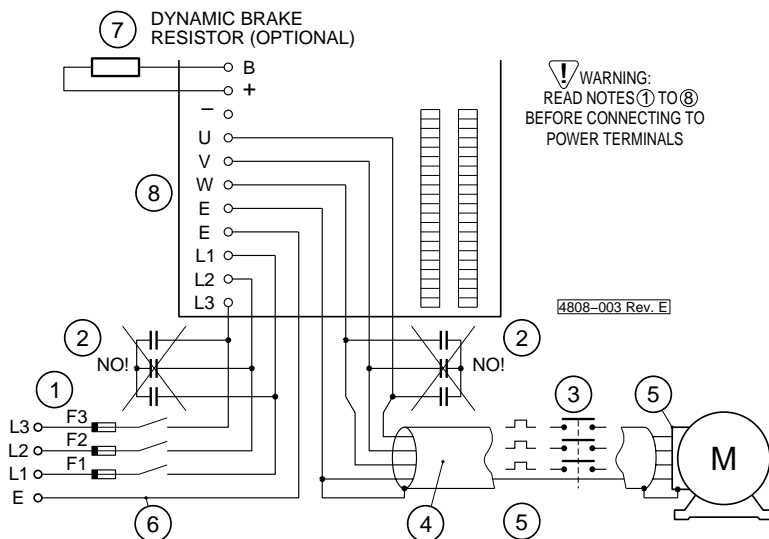

Figure 1.4: Power Wiring and Dynamic Brake Connections

MODEL	MAXIMUM RATED INPUT CURRENT (A)	RECOMMENDED FUSE RATING (A)	RECOMMENDED CABLE SIZE (mm <sup>2</sup> )
ME-2.5	3.1	6	2.5 - 4
ME-6.5	8.1	16	2.5 - 4
ME-10.5	13.1	25	2.5 - 4
ME-12	15	32	4 - 6
ME-18	22	40	4 - 6
ME-22.5	28	50	4 - 6
ME-31	39	80	6 - 10
ME-38	47	100	10 - 16
ME-46	57	100	16 - 25
UE-60	75	150	25-35
UE-75	95	200	35-50
UE-90	115	200	50-70
UE-115	145	300	70-95
UE-140	175	300	95-120

4202-157 Rev G

Figure 1.5: Fuse Rating Table

### 1.3.2 Motor Rotation

#### USE OF “+” AND “-”

“+” Speed is used to describe speed in the forward direction.

According to IEC34-7, the motor rotates clockwise when:

- viewed from the shaft end
- terminals U1, V1 and W1 or U2, V2 and W2 are connected to the Elite Series output phases U, V, W respectively
- the Elite Series is operating with “+” speed.

“-” is used to describe speed in the reverse direction of the motor.

### 1.3.3 Display Mounting

The display unit may be rotated in 90° increments, to suit the mounting orientation of the Elite Series. The display unit may also be mounted remotely from the drive, to a maximum of 3 metres.

### 1.3.4 Control Wiring

#### Control Wiring Recommendations

Bring the control wiring into the enclosure through the gland plate, and install glands to maintain IP54 integrity. Loom control wiring and power wiring separately, at least 300 mm apart and crossing only at right angles. Control cables must be screened to ensure correct operation. Connect the screen only to the ground at the Elite Series to prevent ground loops.

#### Connection recommendations are:

Maximum tightening torque:	0.5 Nm (4.5 lb-in)
Maximum cable size:	1.5 mm <sup>2</sup> appliance wire (26 - 14 AWG Cu)
Maximum number of cables per terminal:	Two
Cable stripping length:	7 mm (0.28 in)

The default configuration of the digital inputs is active high. i.e., the common of all multi-function input switches should be connected to +24Vdc (Terminal T21).

The External Trip/PTC input must be connected to +24Vdc (Terminal T21) (when set for active high) for the Elite Series to start and run a motor.

### 1.3.5 Earthing of Control 0V

To comply with the requirements of a Class 1 earthing system, the Elite Series control 0V must be linked to earth at some point. Connection of multiple earth points may cause earth loops and should be avoided. An earth link is provided between Terminal T20 and the terminal surround plate and must be removed if not required. Removal will allow the 0V point to float up to ±50Vdc (30Vac) from chassis earth.

### 1.3.6 Shaft Encoder Selection and Mounting

A shaft encoder will be needed if operating the Elite Series in closed loop vector control mode.

**Preferred Specification:****Type:**

Incremental, quadrature, differential push-pull output (line driver output).

**Recommended PPR:**

1000 to 2000 ppr per motor pole pair for directly driven encoder

**Minimum PPR:**

500 ppr per motor pole pair (4 pole motor = 1000 ppr).

**Supply requirement:**

5Vdc 100mA max. (Terminal T30) or 24Vdc 500mA max. (Terminal T36).

**Alternative Specification:****Type:**

Single ended push-pull - will cause a reduction in noise immunity.

**Or:**

Single ended open collector - pulses will be distorted by long cables. For this type of encoder the product of cable length (metres) x maximum frequency (kHz) should not exceed 1500. Absolute maximum cable length is 30 m.

**Fitting of Encoder:**

Fit directly to the motor (using a flexible coupling) or indirectly via a toothed drive belt or similar. Avoid slip, backlash, loose couplings and high shaft loadings. Wiring must be done using shielded twisted cable. Earth the shield at the drive end only. Figure 1.6 supplies connection details.

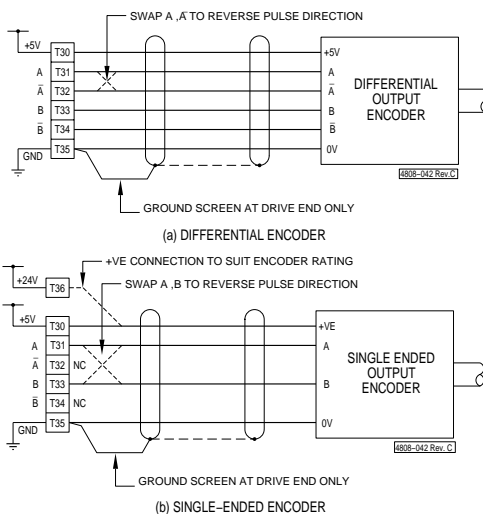

**Figure 1.6:** *Shaft Encoder Connection Details*

### 1.3.7 Fibre Optic Connections

Each Elite Series has an optical input port and output port enabling digitally encoded analogue levels to be passed between drives using plastic fibre optic cable.

Use a knife blade to cut the fibre optic cable to length; insert into the fibre optic port and screw tight the connector.

### 1.3.8 Rubber Control Cable Grommets

Several rubber control cable grommets are provided within the glade plate area of the Elite Series 2.5A to 46A for glanding control cables, fibre optic cables and encoder cables. Cut the tip to the desired diameter for proper sealing around the cable.

### 1.3.9 External Powering of the Control Board

The Elite Series Control Board can be externally energised, by connection of an external +24Vdc (nominal) 1A supply to control terminals T36, T37.

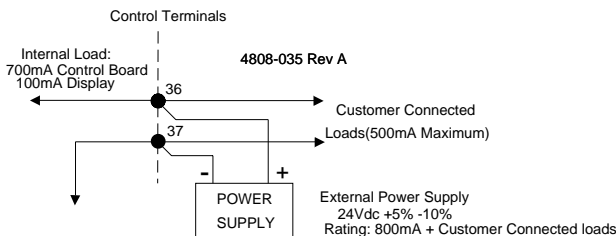

Figure 1.7: External Powering of Control Board

### 1.3.10 Gland Plate and Front Cover Recommended Screw Torques

To ensure that the Elite Series is protected against ingress of dust and splashing water, cable glands must be used and the gland plate and front cover must be tightened to the recommended torque.

Recommended tightening torques are:

MODEL	SCREWS	TORQUES
ME2.5 to 46	Gland Plate Screws (M5) Front Panel Screws (6-32 UNC 28 thread)	3.25 - 3.75 Nm 1.0 - 1.5 Nm
UE60 to 140	Gland Plate Screws (M5) Door Locks	3.25 - 3.75 Nm Quarter turn using key

4202-327 Rev A

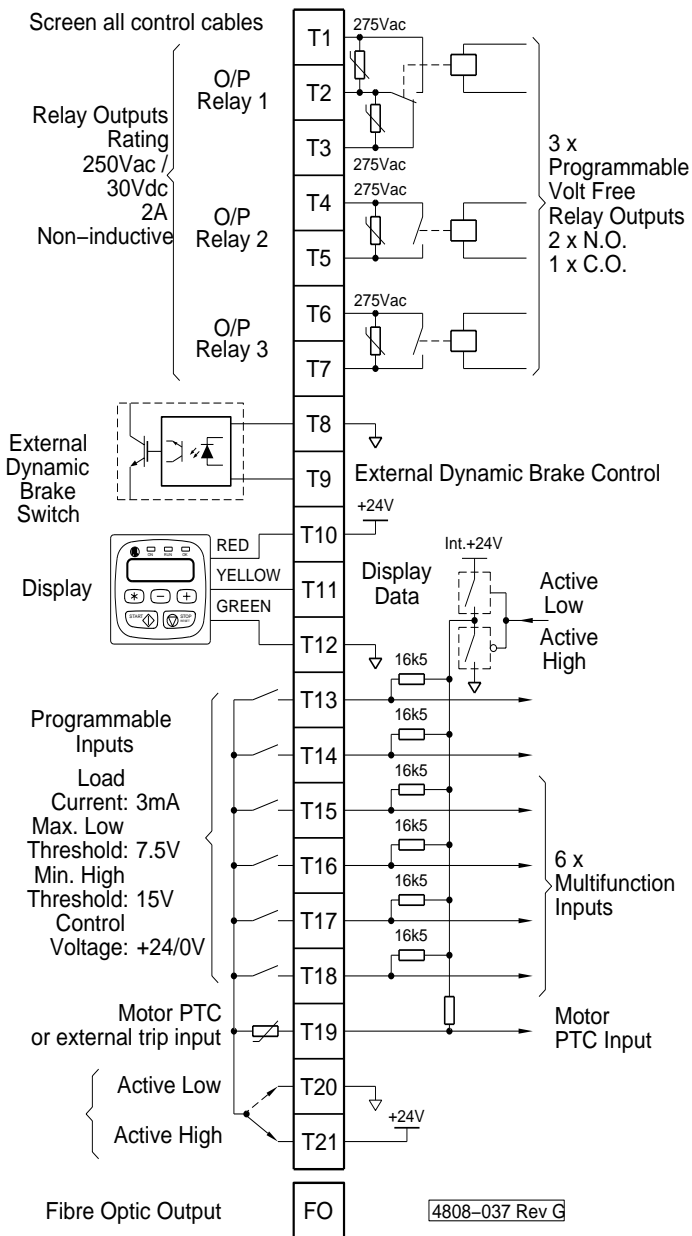

Figure 1.8a: Control Inputs and Outputs



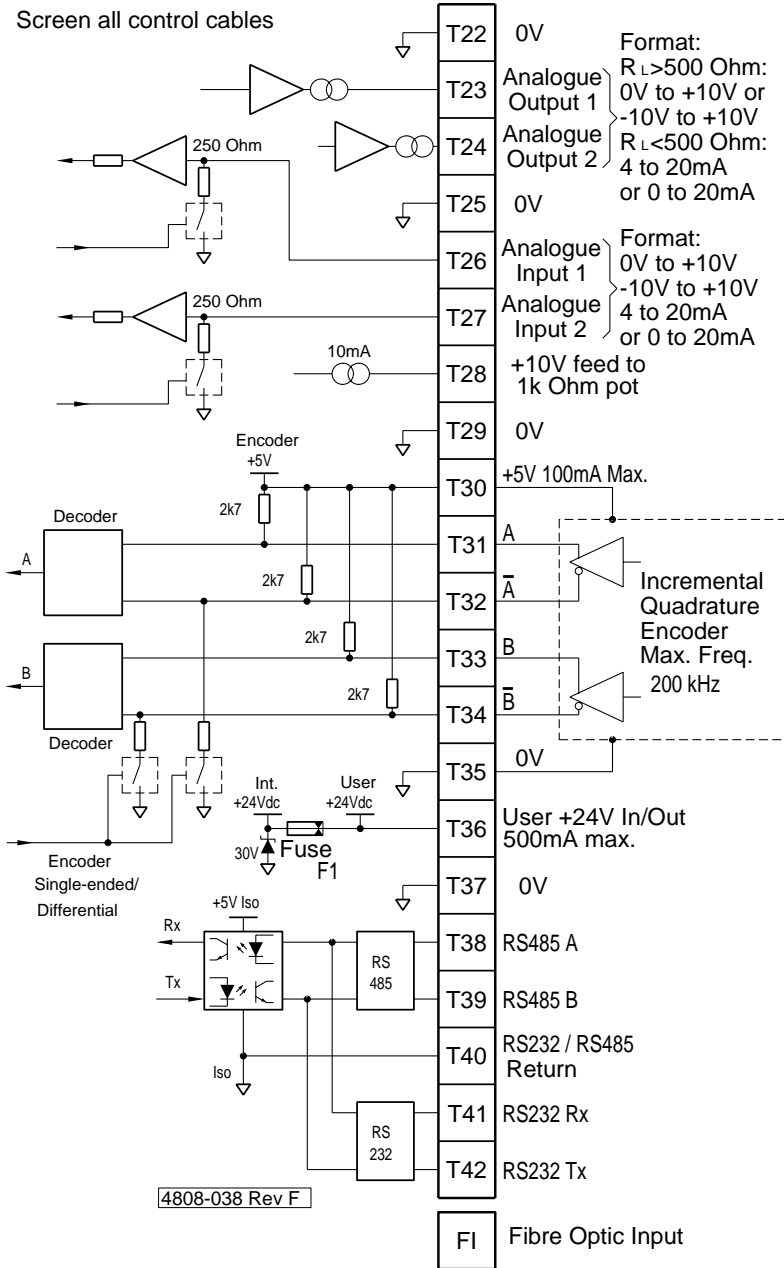

Figure 1.8b: Control Inputs and Outputs

## **Section 2: Operation of the Display Unit**

## 2.1 Display Unit Description

### 2.1.1 The Display Unit and Keys

Refer to Figure 2.1 for Display Unit Details

**STATUS LINE :** Indicates drive status, overload status, output torque, output speed.

**CONTROL LINE :** Indicates screen number, screen description, parameter for adjustment.

#### SCREEN CONTROL KEYS

“+” and “-” keys enable scrolling between screen groups and subscreens.

“\*” allows unfolding of screens if required.

“\*” and “+” or “-” allows individual modes or parameters to be adjusted, if allowed.

#### START / STOP-RESET PUSH-BUTTON

If keyboard control is enabled, these push-button allow starting or stopping/resetting of the Elite Series. This may be in conjunction with external START and STOP push-button.

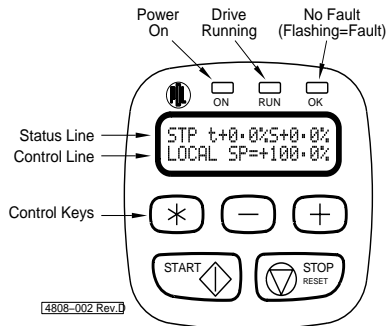

Figure 2.1: Elite Series Display Unit

### 2.1.2 Selection of Screens

Screens are arranged in folded format. Each screen group has a main screen with the group identifying letter and description. Folded under this main screen can be a number of subscreens, each of which has a single parameter or mode for viewing or adjustment. These subscreens cannot be viewed until unfolded. Once unfolded, some subscreens have a numerical parameter which may be adjusted. Others may have a list of options with each option separately viewable and selectable. Extra screens or subscreens may become available when the Elite Series is in “Commissioning” mode.



## 2.2.1 Operating Modes

### OPERATION Mode

This is the normal operating mode of the drive. Each screen will have a pre-configured access right, controlling whether it is hidden, read only, or read-write. Thus operator access to screens can be controlled.

**Read Only:** The screen can be viewed, but not changed.

**Read-Write:** The screen can be viewed and the parameter changed when in OPERATION mode.

**Hidden:** The screen cannot be viewed or changed.

### COMMISSIONING Mode

In this mode, each screen is visible and commissioning parameters may be adjusted, irrespective of the screen's access right. Some parameters are not adjustable while the drive is started or running.

Access to COMMISSIONING Mode may be controlled by a password.

## 2.2.2 Swapping Between OPERATION and COMMISSIONING Modes

### Selecting COMMISSIONING mode before a Password has been set:

Scroll to Main Screen Z.

Z COMMISSION=N

Press "\*" and "+" or "-". The status line should change to:

Z COMMISSION=Y

All screens will now be visible, and all parameters be adjustable.

### Selecting COMMISSIONING mode after a Password has been set:

Figure 2.3 illustrates the procedure for swapping between OPERATION and COMMISSIONING modes using a password.

Scroll to Main Screen Z. The display's control (bottom) line will read:

Z COMMISSION=N

Press "\*" and "+" or "-". The screen will automatically display:  
PASSWORD= ZZZZZ

Now press "\*" and "+" or "-" until the correct password is reached. Then release the keys.

All screens will now be visible, and all parameters be adjustable.

### Selecting OPERATION Mode:

To change from COMMISSIONING Mode to OPERATION Mode, scroll to Screen Group Z.

The display's control line will read:  
Z COMMISSION=Y

Use "\*" and "+" or "-" to toggle to :  
Z COMMISSION=N

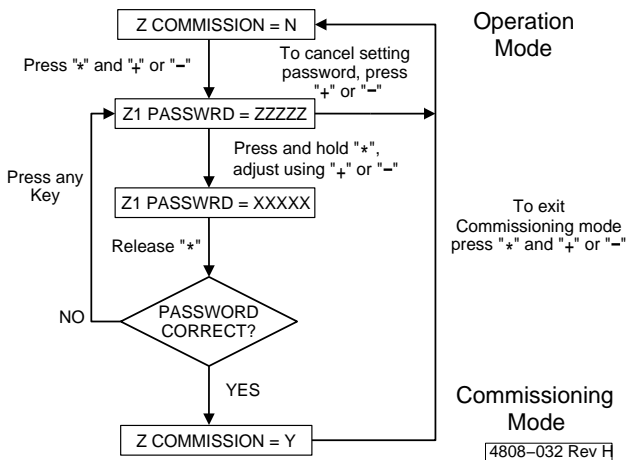

Figure 2.3: Setting Commission Mode after a Password has been set

### 2.2.3 Setting a Password for the First Time

Refer to Figure 2.4.

Once set to COMMISSIONING mode as described above, a password may be set up. Unfold Screen Group Z and scroll to Screen Z1. The display will read: Z1 PASSWORD=OFF

Press "\*" and "+" or "-" to set the required password.

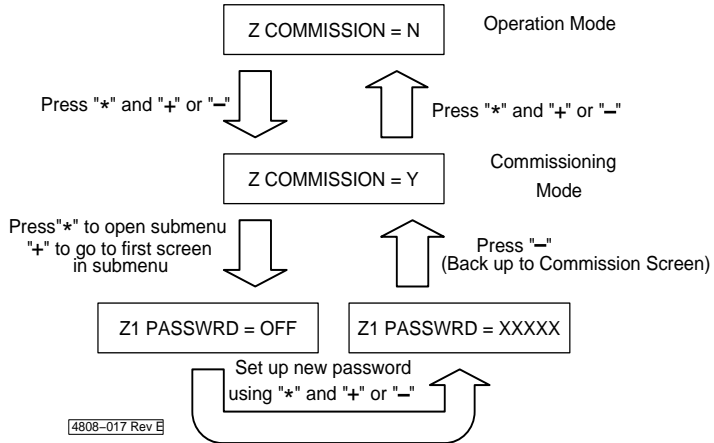

Figure 2.4: Setting a Password for the First Time

### What happens if a password is unknown or forgotten?

Once a password has been entered, a special hashing number is displayed on Screen Z when trying to enter COMMISSIONING mode.

The display will read:  
PASSWORD= ZZZZZ

Take a note of this number and contact a PDL Electronics Applications Engineer, who with suitable authority will be able to pass this code through an algorithm to reconstruct the original password.

## **Section 3: Preliminary Commissioning of the Elite Series**



---

## 3.1 Commissioning Without Motor

### 3.1.1 Foreword

This commissioning guide is not intended to fully commission the Elite Series to its final application. It is intended to prepare the drive to have its final configuration installed (possibly by others).

This commissioning should only be undertaken after all wiring has been completed and verified as detailed in Section 1.

### 3.1.2 Checks Before Powering up

#### CHECK INSTALLATION

Check that the Elite Series will not be subject to an unacceptable environment. Check that adequate cooling airflow is available. Check that no tools, swarf, or hardware have been left in the drive.

#### CHECK POWER WIRING

Check that all supply and motor cabling is correctly dimensioned for the application, the Elite Series is bonded to earth, and electrical connections are secure. The cable between the Elite Series and motor should be of screened construction, with the screen (forming the earth connection) solidly bonded to the motor and the Elite Series chassis. Ensure that the motor and power wiring are not transposed. Note that the Elite Series does not have internal power fuses. Check that the correct fuses (Figure 1.4) are fitted at the supply.

#### CHECK CONTROL WIRING

Control wiring must be screened and run separately from power cables. Check that there are no loose strands, and that all terminal screws or bolts have been tightened. Check that the control wiring conforms to the required configuration – active high or active low. Note that the default configuration is active high.

**WARNING:** If the previous setup of the Elite Series is not known – remove the link from the External Trip Input (Terminal T19). This will trip the unit and prevent possible instantaneous starting of the motor upon applying power to the Elite Series.

### 3.1.3 Applying Power to the Elite Series

**BEFORE PROCEEDING, ISOLATE THE MOTOR.** Switch on the mains supply to the Elite Series.

#### CHECK DRIVE OPERATION

Check that the cooling fan is blowing air through the heatsink. Check that the display lights up. Check that the DC Bus Live LED is glowing red. Screen A4 will be initially displayed (unless the Elite Series has tripped on a protective function).

## 3.2 Preliminary Control Setup

### 3.2.1 Foreword

The Elite Series has an advanced and adaptable set of motor control features.

A very flexible set of options for configuration of the digital, analogue and fibre optic inputs and outputs; coupled with multiple ramp rates and start/stop modes allows the user to modify the Elite Series motor controller to suit their process control system.

The adaptability of the Elite Series permits the user to tailor the performance requirements through selecting V/Hz or Open Loop Vector control mode (Speed control) and the Closed Loop Vector control modes (Speed and Torque control).

The screen list is shown in Appendix 1.

Before proceeding, ensure that the Elite Series is in COMMISSIONING mode. Refer to Section 2.2.2 for details.

### 3.2.2 Checking of Analogue Inputs

If analogue inputs are being used to control the Elite Series, they must have their format correctly configured. By default, Analogue Input 1 is 0 to 10Vdc, and Analogue Input 2 is 4 to 20mA. These may be re-configured if necessary by using Screens I6a (Analogue Input 1) and I6d (Analogue Input 2).

Once correctly configured, the Analogue Input 1 (Terminal T26) and Analogue Input 2 (Terminal T27) can be checked by observing Screen Z3 (refer Figure 3.1) and Screen Z4 respectively.

Reference 1: Indicates the relative level of the Analogue Input in percent

For  $\pm 10\text{V}$  input,             $-10\text{V} = 0\%$ ;     $+10\text{V} = 99\%$   
 For  $0\text{-}10\text{V}$  input,             $0\text{V} = 0\%$ ;     $+10\text{V} = 99\%$   
 For  $0\text{-}20\text{mA}$  input,           $0\text{mA} = 0\%$ ;     $20\text{mA} = 99\%$   
 For  $4\text{-}20\text{mA}$  input,           $4\text{mA} = 0\%$ ;     $20\text{mA} = 99\%$

Reference 2: Indicates the actual input level either in Volts or mA

For voltage input,             $-10\text{V}$  to  $+10\text{V}$   
 For current input,             $0\text{mA}$  to  $20\text{mA}$

Z	3		A	I	1	=	9	9	=	+	9	.	9	V		Control line
Z	4		A	I	2	=	9	9	=		+	2	0	m	A	Control Line
							1									Reference
															2	

4202-168 Rev A

Figure 3.1: Screens Z3, Z4 – Analogue Input Status

### 3.2.3 Checking of Analogue Outputs

If analogue outputs are being used, their formats must be correctly configured on the Elite Series Control Board to suit the devices they are driving. Both outputs may be configured for 0-10Vdc, -10 to +10Vdc, 4 to 20mA or 0 to 20mA. These format configurations can be done from Screens O1b (Analogue Output 1), and O1f (Analogue Output 2).

Once their respective formats are configured, the operation of the outputs can be confirmed as follows. For Analogue Output 1, scroll to Screen O1a, and select Mode 1 (Full Scale). For Analogue Output 2, scroll to Screen O1e and select Mode 1 (Full Scale). This should cause the respective analogue outputs to be driven to their maximum. Check that the driven devices are driven to their full scale. When these tests are complete, restore Screens O1a, O1e to the required modes (if known).

Once correctly configured, the Analogue Output 1 (Terminal T23) and Analogue Output 2 (Terminal T24) can be checked by observing Screen Z5 (refer Figure 3.2) and Screen Z6 respectively.

Reference 1: Indicates the relative level of the Analogue Output in percent

For  $\pm 10V$  output,      -10V = 0%;    +10V = 99%  
 For 0-10V output,        0V = 0%;     +10V = 99%  
 For 0-20mA output,      0mA = 0%;    20mA = 99%  
 For 4-20mA output,     4mA = 0%;    20mA = 99%

Reference 2: Indicates the actual output level either in Volts or mA

For voltage output,      -10V to +10V  
 For current output,      0mA to 20mA

Z	5	A	O	1	=	9	9	=	+	9	.	9	V	Control line
Z	6	A	O	2	=	9	9	=		+	2	0	m A	Control Line
							1							Reference
							2							

4202-174 Rev A

Figure 3.2: Screens Z5, Z6 – Analogue Output Status

### 3.2.4 Checking of Digital Inputs

Scroll to Screen Z7 (refer Appendix 1). The six characters on the left of the bottom row of characters show the states of the six digital inputs. Refer to Figure 3.3, references 1 to 6.

Reference 7 in Figure 3.3 shows the state of the motor PTC thermistor. If no thermistor or other external trip device is fitted, the corresponding control terminal (T19 on the Control Board) should be CLOSED: i.e., linked to +24Vdc (Terminal T21) when configured for ACTIVE HIGH, or linked to 0V (Terminal T20) when configured for ACTIVE LOW.

A “X” represents CLOSED and indicates that the digital input is connected to the circuit common (+24Vdc for ACTIVE HIGH or 0V for ACTIVE LOW).

A “O” represents OPEN and indicates that the digital input is NOT connected to the circuit common (+24Vdc for ACTIVE HIGH or 0V for ACTIVE LOW).

Check that each switch in turn, when operated, closes the correct circuit, and check that the multi-function input switch wiring configuration corresponds to what has been set on Screen I7b POLARITY=H/L.

Z	7		M	F	I	:	X	O	O	X	O	X		X		Control line
							1	2	3	4	5	6		7		Reference

4202-175 Rev A

Figure 3.3: Screen Z7 – Digital Input Status

### 3.2.5 Checking of Digital Outputs

If any of the three output relays are being used for remote status indication, they will need checking for correct operation. For Relay 1, scroll to Screen O2a, and select Mode 1 (ALWAYS ON) and relay not inverted on Screen O2b. This should force the relay ON, and the external connected device should reflect this. Set up Relays 2, 3 in the same way, using Screens O2c to O2f respectively. When these tests are complete, restore Screens O2a to O2f to the required modes (if known).

Screen Z10 reflects the status of the output relays. References 1, 2, 3 of Figure 3.4 refer to Relays 1, 2, 3 respectively.

Z	1	0		R	L	Y	:	O	X	X		D	B	:	O	Control line
								1	2	3					4	Reference

4202-176 Rev A

Figure 3.4: Screen Z10 – Digital Output Status

### 3.2.6 Preliminary Setup

Initially, the motor should be energized and controlled without using any external input devices. Thus it is recommended to set up for operation under front panel control. This is achieved by setting up the following screens:

N1 to N5 Motor Current, Volts, Frequency, kW, RPM.

Copy from the motor’s rating plate.

- I1 LOCAL S/STP=3 (enables local keyboard Start/Stop-Reset)
- I2 REF S = LOCAL (reference speed source = local keyboard)
- I7a I/P MODE= 0 (Local control only) (disables all multi-function puts)

- A3 LOCAL SP = 0% (sets local speed to zero)
- A1 LOCAL MODE = SP (sets to speed control mode)
- X1 CONTROL TYPE= 02 V/Hz (sets for V/Hz speed control mode)

This configures the operation mode to V/Hz speed control mode. If open or closed loop vector operation mode is required, this parameter should be set correctly later.

### 3.2.7 Shaft Encoder Configuration

If a shaft encoder is to be used to operate the Elite Series in closed loop vector control mode, appropriate configurations must be programmed as follows:

#### Type of Encoder:

The type of encoder (single ended output or differential output) must be identified, and programmed into Screen N9.

#### Encoder Pulses per Revolution:

This parameter must be programmed into Screen N8, as the encoder pulses per revolution of the motor shaft. If the encoder is driven directly from the motor shaft, then this figure will be the shaft encoder pulses per revolution. If the encoder is indirectly driven, for example by a toothed belt and pulley arrangement, then any ratio change must be accounted for. If it is impossible to determine the drive ratio between the motor shaft and the encoder shaft, then the ratio may be calculated by carefully turning the motor shaft through an exact number of revolutions, and observing the change in count on Screen Z9. Divide the count change by the number of revolutions of the motor shaft, and enter the result into Screen N8.

### 3.2.8 Dynamic Brake Configuration (if fitted)

If a dynamic brake has been installed in conjunction with the Elite Series, configure by setting Screens D1, D2.

- D1 DB Time Constant Time that the brake resistor will take to reach 64% of its final temperature if continuously energized.
- D2 DB Duty Average percentage of time that the resistor may be energized for, without damage (when averaged over periods long in comparison to the time constant).

If the dynamic brake resistor has been supplied by PDL Electronics Ltd., the suggested settings will have been supplied. If a dynamic brake has not been fitted, leave at the default values.

If the dynamic brake is being used check the status on Screen Z10 (Z10 RLY:OXX DB:X) during normal operation. A Closed (X) status indicates that the dynamic brake has operated since the last screen update. An Open (O) status indicates that the dynamic brake has not operated since the last screen update.

### 3.2.9 Checking of Fibre Optic Input

Screen Z8 displays the status of the Fibre Optic Input (and the Serial input).

If the fibre optic input port is being used as a speed or torque reference then check that an X is displayed on Screen Z8 (Z8 FI:X SERIAL:O). A Closed (X) status indicates that a valid fibre optic data packet has been received since the last screen update. An Open (O) status indicates that no valid data packet has been received since the last screen update. An X (Closed) should be displayed at all times when the fibre optic input is receiving valid data.

#### 3.2.10 Checking of Serial Input

Screen Z8 displays the status of the Serial Input (and the Fibre Optic input).

If the serial port is being used check that an X is displayed on Screen Z8 (Z8 FI:O SERIAL:X). A Closed (X) status indicates that a valid serial data packet has been received since the last screen update. An Open (O) status indicates that no valid data packet has been received since the last screen update.

## 3.3 Energising the Motor

### 3.3.1 Connecting the Motor

**WARNING:** Check that all personnel are clear of the motor and attached machinery, and that it is safe to operate the motor. If the motor is out of sight of the Elite Series motor controller, it may be necessary to have someone in radio or telephone contact with yourself standing by the motor, to ensure safety and to report any unusual occurrences.

Remove the isolation from the motor. If the motor has been disconnected, power down the Elite Series, allow to discharge, and reconnect the motor terminals. Power up the drive and proceed.

START the Elite Series by using the front panel START push-button. Scroll to Screen A3 and increase the set speed by pressing “\*” then “+”. Check that the motor is turning in the expected (forward) direction. If not, STOP the drive, power it down, wait for discharge, and swap any two motor terminations over. Power up the drive and proceed.

### 3.3.2 Checking the Shaft Encoder (if fitted)

If a shaft encoder is fitted to the motor (i.e., for operation in closed loop vector mode) check that the encoder is correctly connected.

Check Screen Z9. It should be indicating a changing encoder pulse count. If this screen does not register any change in count, even though the motor is turning, check the encoder mechanical coupling and electrical connections.

If the motor is running in a forward direction (indicated by REF SPD, displayed by Screen A4, being +ve) the encoder count (Screen Z9) should be counting UP. Also the status (top) line of the display should indicate a +ve actual speed. If the encoder is indicating that the motor is running in a reverse direction, but in fact the motor is running in the preferred forward direction, swap two encoder outputs. For a differential output type shaft encoder, either swap wires into control terminals T31, T32 (A, /A) or swap wires into terminals T33, T34 (B, /B). For a single-ended output type encoder, that does not have /A, /B outputs, swap wires into terminals T31, T33 (A, B).

Stop the motor by using the Display Unit STOP-RESET push-button.

### 3.3.3 Autotuning

The motor must be correctly characterised for good dynamic performance. This can be done automatically by the Elite Series. Autotuning is controlled from Screen X2.

Autotuning will automatically set optimum values for the following parameters (without turning the motor):

X3a	Lm	Motor Main Inductance
X3b	Rs	Stator Resistance
X3c	Rr	Rotor Resistance
X3d	SIGMA	Total Leakage Inductance

The motor must be stopped for Autotuning to function correctly.

**WARNING:** Autotuning applies voltage to the terminals of the motor. Check that all personnel are clear of the motor and attached machinery, and that it is safe to operate the motor.

Screen X2 selects AUTOTUNE options, as follows:

X2	AUTOTUNE = NO	Autotuning not active
	AUTOTUNE = YES	This tunes the motor without moving the motor.

Autotuning may take several seconds to complete.

### 3.3.4 Preliminary Commissioning Complete

The Elite Series motor controller has now been completely installed and checked. The unit is now ready for final commissioning.

## **Section 4: Final Commissioning of the Elite Series**



## 4.1 Operation Mode and Configuration

Figure 4.2 summarises the Screen List available by default. Full descriptions of all screens are given in the Elite Series Technical Manual, PDL Part No. 4201-180.

### 4.1.1 Operation Modes

The Elite Series may be set up to run in one of four operation modes. These are shown in Figure 4.1.

#### Open Loop Vector Operating Mode:

For general-purpose speed control applications, e.g. pumps, fans, conveyors etc. A shaft encoder is not needed. Configuration to this mode is set by programming Screen X1 to Open Loop Vector.

#### V/Hz Operating Mode:

For general-purpose speed control applications, e.g. pumps, fans, conveyors etc. A shaft encoder is not needed. This open loop speed control mode generates an output with a fixed voltage vs frequency profile. Suitable for running multiple parallel motors from one Elite Series. Select by setting Screen X1 Control Type = 02-V/Hz.

Also use V/Hz mode when autotuning an Elite Series motor controller.

#### Closed Loop Vector Mode - Torque Control:

For use in torque control applications, e.g. winder systems, position control applications with an external speed-position controller. A quadrature shaft encoder will be required on the motor, to provide rotor position feedback.

To set up this mode of operation, set the encoder pulses per motor shaft revolution on Screen N8 and program Screen X1 to Closed Loop Vector. Then select torque control mode, either by appropriately configuring one of the multi-function inputs (Screen I7c to I7h, Selection 16 Speed/Torque Mode) and activating the switch, or by setting for torque control mode (Screen A1 LOCAL MODE=TQ).

#### Closed Loop Vector Mode - Speed Control:

Recommended for servomotor type applications, where fast dynamic response is required, and for crane hoists and other applications where full torque capability at zero speed is required. A quadrature shaft encoder is required on the motor, to provide rotor position and speed feedback.

To set up this mode of operation, set the encoder pulses per motor shaft revolution on Screen N8 and program Screen X1 to Closed Loop Vector. Then select speed mode, either by appropriately configuring one of the multi-function inputs (Screen I7c to I7h, Selection 16 Speed/Torque Mode) and deactivating the switch, or by setting for speed control mode (Screen A1 LOCAL MODE=SP).

When operating in closed loop vector mode, switching between speed control and torque control modes can be done without stopping the Elite Series.

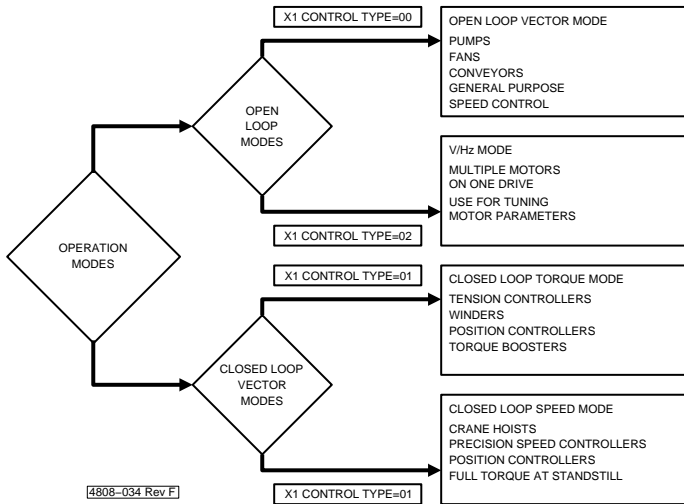

Figure 4.1: Elite Series Operation Modes

### 4.1.2 Input Configuration

If Start–Stop/Reset is not required from the display unit, set Screen I1. (Refer to Elite Series Technical manual 4201-180).

Select the required speed or torque reference source from Screen I2, I3. If an alternative source is required, e.g. for local/remote or auto/manual control, select from Screens I4, I5.

If Analogue Input 1 is to be used as a reference source, set format and scaling from Screens I6a, I6b, I6c. Similarly, Screens I6d, I6e, I6f set up Analogue Input 2.

If a zero band is required, set on Screen I6g. This sets a definite zero speed or zero torque region when using either analogue input.

If the fibre optic input is to be used as a reference source, set scaling from Screens I8a, I8b.

Configure the multi-function inputs (MFIs) from Screens I7. Screen I7a programs the MFIs in groups, while I7c to I7h programs each individually.

Configure the MFIs for active high or active low from Screen I7b.

### 4.1.3 Output Configuration

Select the function, format and scaling of Analogue Output 1 from Screens O1a, O1b, O1c, O1d. Similarly, Screens O1e, O1f, O1g, O1h set up Analogue Output 2.

---

Select the required output relay functions from Screens O2a, O2c, O2e, and their sense from Screens O2b, O2d, O2f.

If using the fibre optic output, set function and scaling from Screens O3a, O3b, and O3c.

#### **4.1.4 Acceleration and Deceleration Rates**

If operating the Elite Series as a speed controller, set required acceleration and deceleration rates from Screens R1, R2. Generally, set for the required response without torque limiting when accelerating (indicated by TLT on status line of display) and without excess regeneration on deceleration (indicated by VLT on status line). These rates active only when speed controlling.

If two rates are required, set alternative rates and break speed on Screens R3, R4, R5.

Set required deceleration rate when emergency stopping on Screen R6.

#### **4.1.5 Speed and Torque Limits**

Set speed limits by Screens L2, L3. Normally set outside the range of the reference speed input. Should be active only when in torque control mode on light load. Indicated by SLT on status line of display.

Set torque limits by Screens L4, L5. Normally set outside the range of the torque reference input. Should only be active when in speed control modes, on overloads (indicated by TLT on status line of display). Also torque limiting becomes active on loss of shaft encoder pulses when running in closed loop vector mode.

Set speed limit timeout on Screen L6. Drive will trip if speed limiting exceeds this time.

Set torque limit timeout on Screen L7. Drive will trip if torque limiting exceeds this time. Provides protection against loss of shaft encoder pulses.

#### **4.1.6 Multi-references**

Set Screens M1 to M7 in conjunction with certain input modes (Screens I7) as preset torque or speed references.

## 4.2 Closed Loop Vector Speed Loop Tuning

If operating the Elite Series in vector speed control mode, the speed feedback loop proportional, integral and derivative parameters (Screens X4f, X4g, X4h) will require tuning. Default values will give stable but not optimum performance.

### 4.2.1 Speed Loop Proportional Gain (Screen X4f)

If possible, decouple the load, and start the Elite Series. Set to a speed greater than 50%. Now increase proportional gain (Screen X4f Kp w) slowly until the motor is heard to go unstable. This instability can also be noticed on the status line of the display unit, by the indicated speed starting to jump around. Note the setting of Screen X4f at this point, and back off the setting to 50% of this value.

### 4.2.2 Speed Loop Integral Gain (Screen X4g)

Once Screen X4f is set as described above, set to a speed greater than 50%. Scroll to Screen X4g Ki w and increase the integral gain slowly until the motor is heard to go unstable. This instability can also be noticed on the status line of the display unit, by the indicated speed starting to jump around. Note the setting of Screen X4g at this point, and back off the setting to 80% of this value.

### 4.2.3 Speed Loop Derivative Gain (Screen X4h)

The derivative gain will only need adjusting if extremely fast response is required. Set up very fast ramp rates (Screens R2, R4, R6 =6000%/s) and stop the drive while observing the motor shaft. Any tendency for the shaft to oscillate on stopping can be damped by adjusting Screen X4h Kd w.

### 4.2.4 Use of Analogue Output in Tuning Speed Loop

If it is not possible to observe the motor or load from the location of the Elite Series, the motor speed may be observed by programming an analogue output to indicate motor speed (Screen O1a or O1e). Set the output format for 0-10Vdc (Screen O1b or O1f). Set the output span from 0% to +100% (Screen O1c, O1d or O1g, O1h). Now connect an oscilloscope to the analogue output and observe speed response to tuning parameter variation on the oscilloscope. Also check response to step changes in speed reference.

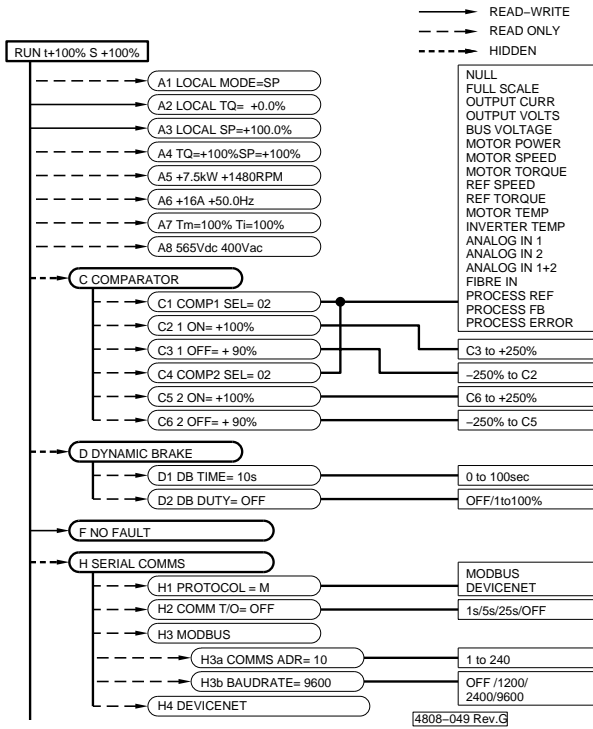

Figure 4.2: Default Screen Lists A-H

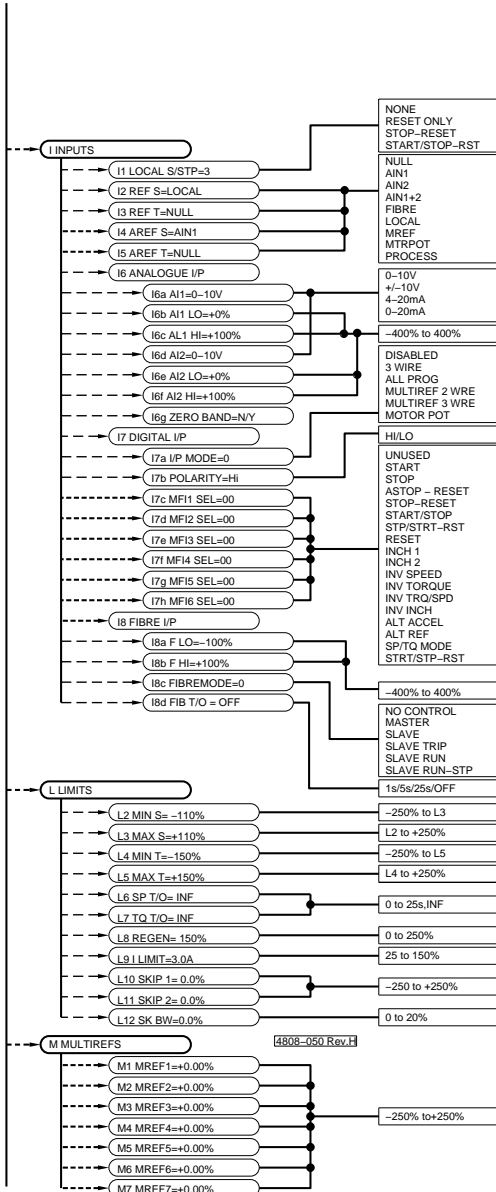

Figure 4.3: Default Screen Lists I-M

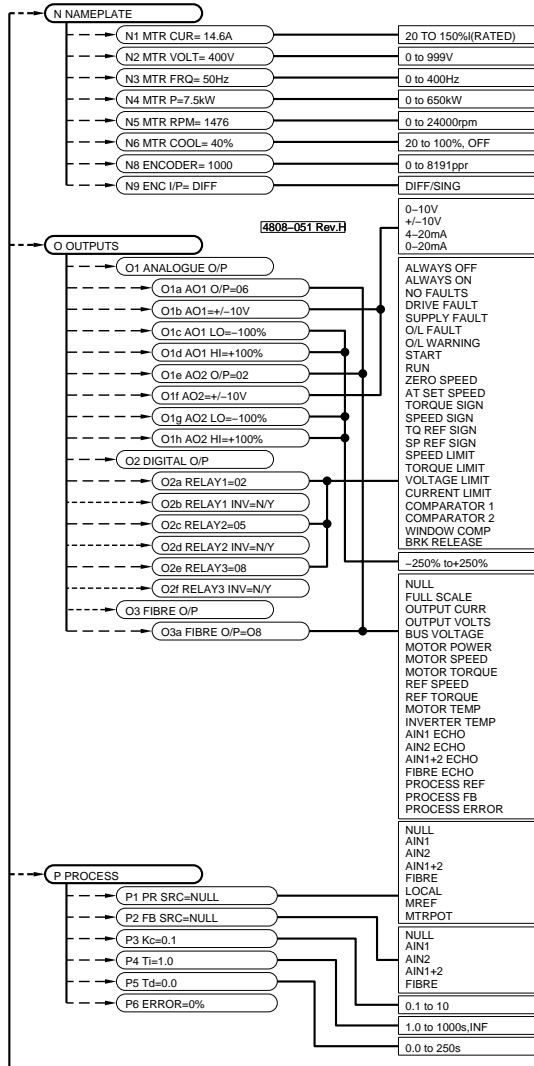

Figure 4.4: Default Screen Lists N-P

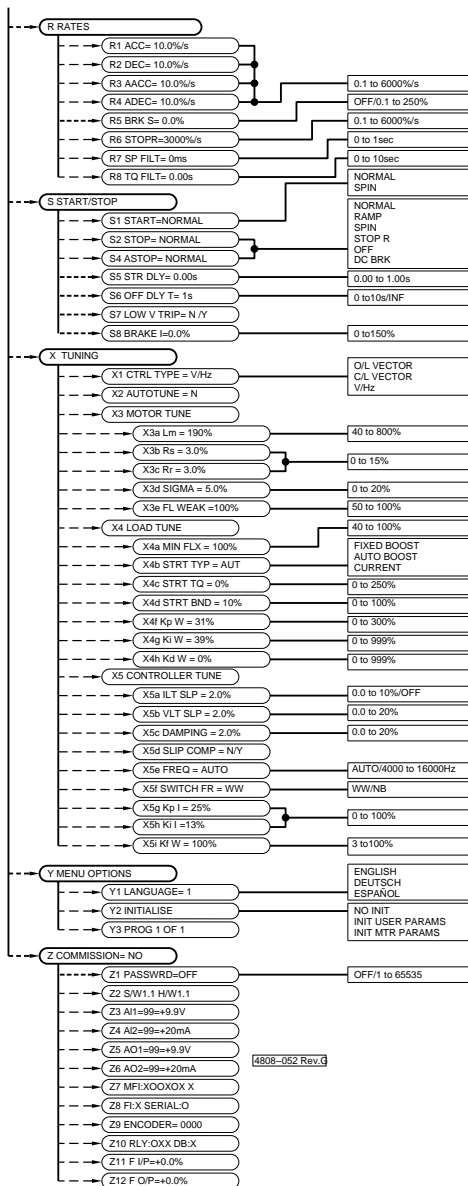

Figure 4.5: Default Screen Lists R-Z





**PDL Electronics Ltd** **Head Office: 81 Austin Street, Napier, New Zealand.**

Tel: +64-6-843-5855 Fax: +64-6-843-5185

Sales branch offices in Auckland, Christchurch and Wellington.

**FREephone: 0800-737-356 (New Zealand only)**Internet: <http://www.pdl-elec.co.nz>**Australia:** Sales branch offices in Adelaide, Melbourne, Perth and Sydney.

Brisbane Head Office: Tel: +61-7-868-2311 Fax: +61-7-868-2366

Customer Service Hotline: 1800-644-677 (Australia only)

**Germany:** Nuremberg Tel: +49-9128-91990 Fax: +49-9128-919980*Specifications are subject to change without notice.*